

Lebanese American University
Faculty of Engineering and Architecture
Electrical and Computer Engineering Department

Course: ELE 201 Electrical Circuits I

Exam 1

Thursday 16 April, 2009

NAME:

ID:

Time: 70 min

Exam Rules

No cell-phones.

No graphical or programmable calculators.

Honor Code

All homework assignments and exams should be done on an individual basis unless explicitly stated otherwise by the instructor. Cheating is a very serious offense and will not be tolerated. The University policy concerning cheating is as follows:

“Students caught cheating on an exam receive a grade of zero on the exam in their first cheating attempt in the course and receive a warning. Students caught cheating for the second time in the same course receive a grade of F in the course and a second warning. A grade of zero on an exam resulting from cheating must be counted in the student’s course grade. The zero cannot be dropped in computing the final grade in case the instructor has a policy of allowing students to drop their worst exam grade.”

In addition: A repeated offense in either the HW’s or the quizzes will be punished by getting an F on ALL HW’s or quizzes respectively.

Any similarity in a homework or quiz will be considered a cheating attempt.

Lebanese American University
Faculty of Engineering and Architecture
Electrical and Computer Engineering Department

Problem 1 (15 points)

- a) Find the resistance at the terminals when the switch is open
- b) Find the resistance at the terminals when the switch is closed

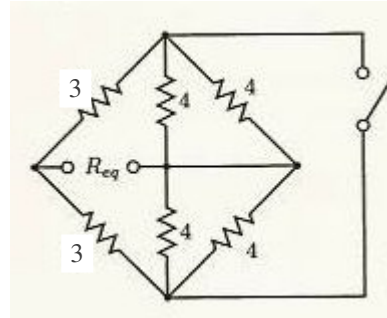

Lebanese American University
Faculty of Engineering and Architecture
Electrical and Computer Engineering Department

Problem 2 (10 points)

Find V_x using power conservation.
 Specify if each element supplies or uses energy.

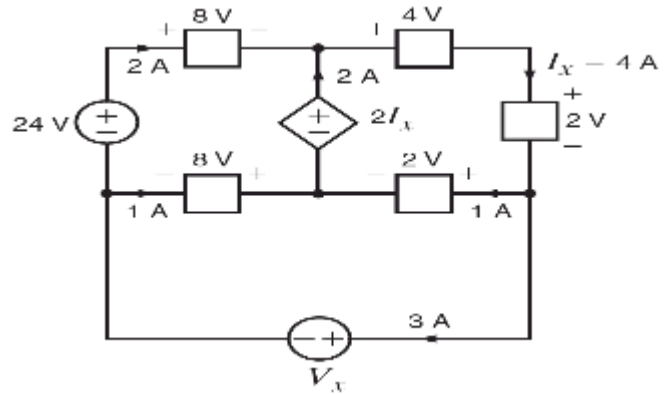

Lebanese American University
Faculty of Engineering and Architecture
Electrical and Computer Engineering Department

Problem 3 (15 points)

- a) Find I_o .
- b) Find V

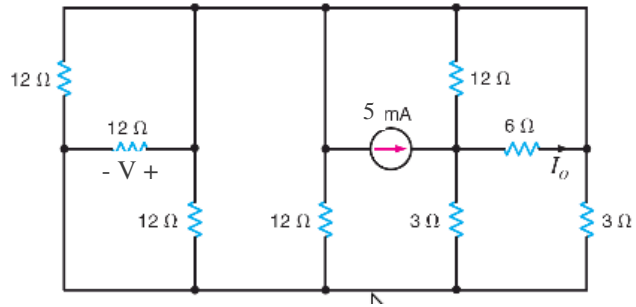

Lebanese American University
Faculty of Engineering and Architecture
Electrical and Computer Engineering Department

Problem 4 (20 points)
Find V_o using Node analysis

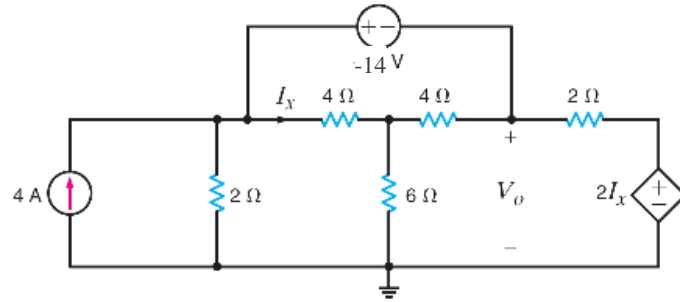

Lebanese American University
Faculty of Engineering and Architecture
Electrical and Computer Engineering Department

Lebanese American University
Faculty of Engineering and Architecture
Electrical and Computer Engineering Department

Problem 5 (20 points)
Find V_o using Mesh analysis.

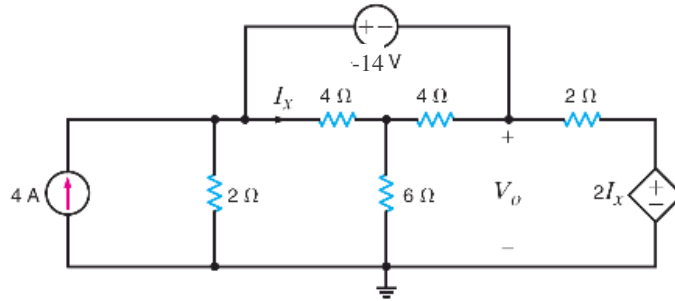

Lebanese American University
Faculty of Engineering and Architecture
Electrical and Computer Engineering Department

Lebanese American University
Faculty of Engineering and Architecture
Electrical and Computer Engineering Department

Problem 6 (20 points)
Write the equations needed
to solve for I_0 using Mesh
Analysis.

