

Experiment 5

Diode Rectifier Circuits

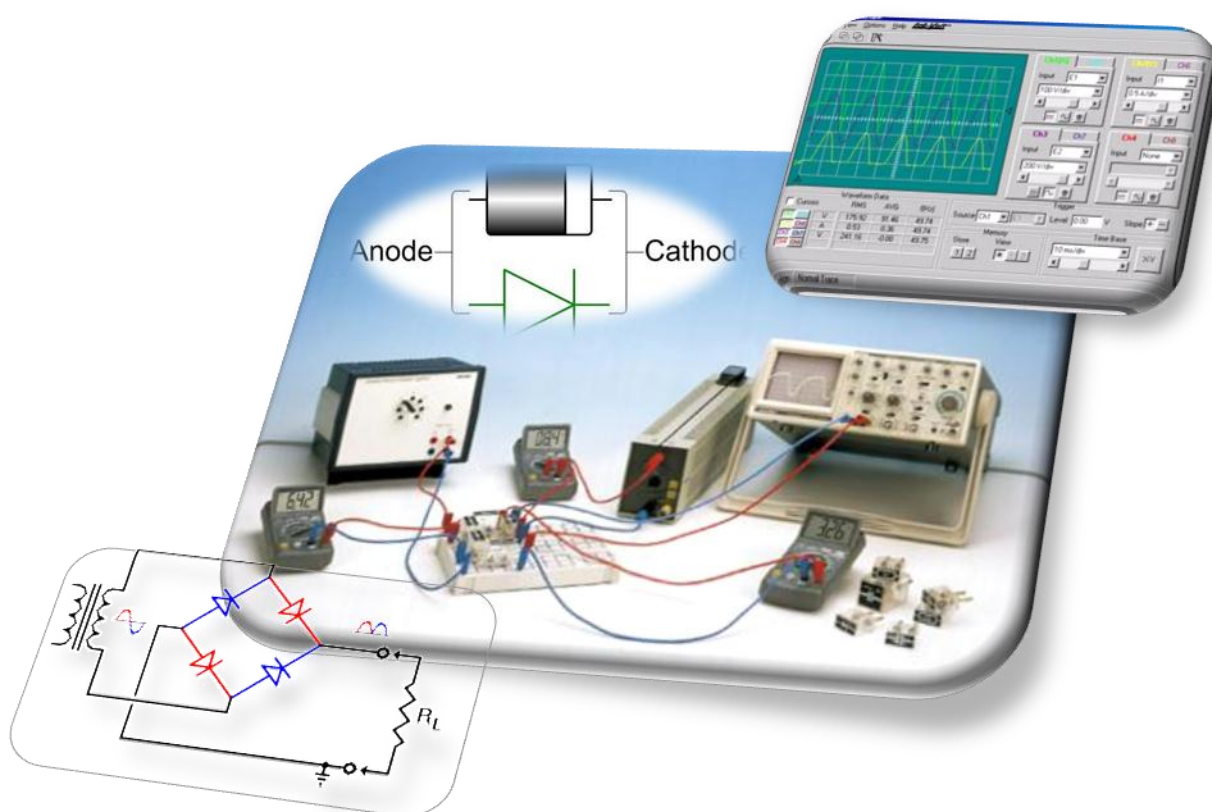

Table of Contents

I. Objectives	3
II. Theory	3
III. Material and Procedure.....	4
A. Rectifier Characteristics	4
B. Full Wave Rectifier with Capacitor	6
B1. Full Wave Rectifier with Capacitor Calculations	6
B2. Full Wave Rectifier with Capacitor Measurements.....	6
IV. Outcomes	8

I. OBJECTIVES

In this experiment you will learn how to:

- Measure and calculate all the characteristics of the half-wave rectifier.
- Measure, calculate, and compare the characteristics of full-wave rectifiers.
- Measure and calculate the characteristics of a rectifier with a capacitor filter.
- Design a rectifier circuit with a capacitor filter by proper choice of the transformer secondary voltage and the capacitance value.

II. THEORY

A rectifier circuit converts an alternating input to a unidirectional output. This may be accomplished by using unidirectional devices, which allow the passage of current in one direction through the device but not in the opposite direction. The most common types of unidirectional devices are semiconductor diodes. Ideally, a diode behaves as a perfect switch. In the forward direction it has a zero resistance and zero offset voltage. In the reverse direction, it behaves as an open circuit.

Note *The half-wave rectifier blocks the negative variations of the input; the output is approximately equal to the input when the input is positive, and is zero otherwise. In the full-wave rectifier, on the other hand, the output is approximately equal to the absolute value of the input.*

The most important characteristics which must be specified for a rectifier circuit are:

1. DC output voltage.
2. Ripple-factor, defined as a ratio of the peak-to-peak ripple (voltage variation in the output) to the average voltage across the load.
3. Average and peak currents in each diode.
4. Peak inverse voltage (PIV) for each diode.
5. Percent regulation, defined as $\frac{V_0 - V_L}{V_L}$, where V_0 is the no-load voltage and V_L is the full-load voltage.
6. Transformer requirements, such as the secondary winding voltage and current ratings.

It should be carefully noted that these characteristics, depend, in general, upon the type of load connected to the rectifier output, i.e., whether it is resistive, capacitive or inductive.

A transformer is used for stepping-down the input AC voltage. It is a device that transmits AC power from one circuit to another through magnetic coupling, often with no conductive connection. The transformation process obeys the relationships:

$\frac{V_2}{V_1} = \frac{N_2}{N_1}$ and $\frac{I_2}{I_1} = \frac{N_1}{N_2}$ where subscripts 1 and 2 refer to the primary and secondary sides, respectively.

Experiment 5

A capacitor can be connected at the output of the rectifier to smooth the voltage variations. An approximate analysis for a full-wave rectifier with a capacitor filter gives the following:

$$\text{PEAK-TO-PEAK RIPPLE VOLTAGE: } V_r \approx \frac{V_{2max}}{2fR_L C}$$

$$\text{DC VOLTAGE: } V_{DC} \approx V_{2max} - \frac{V_r}{2}$$

$$\text{DC CURRENT: } I_{DC} = \frac{V_{DC}}{R_L}$$

where V_{2max} is the peak AC input voltage (at the secondary of the transformer), R_L is the load resistance, C is the filter capacitance, and f is the frequency of the AC voltage.

III. MATERIAL AND PROCEDURE**A. RECTIFIER CHARACTERISTICS****Procedure**

- For each of the circuits in Figs A-1, A-2, and A-3 adjust the load resistor to get $I_{DC} = 50$ mA. Observe the output across the load on the oscilloscope and determine each of the quantities 1 to 4 mentioned in the Theory section above.
- For each of the circuits in Figs A-1, A-2, and A-3, change the DC current from 50 mA to 0 by opening the load connection, and determine the percent regulation.

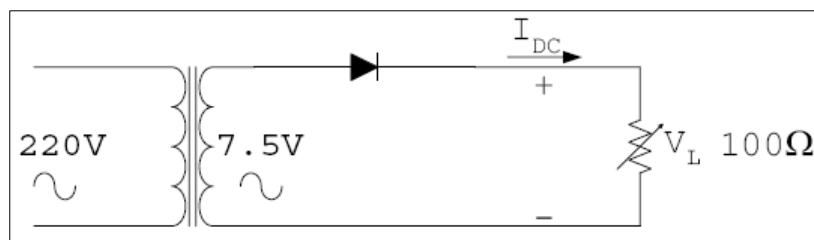

Figure A-1: Half Wave Rectifier

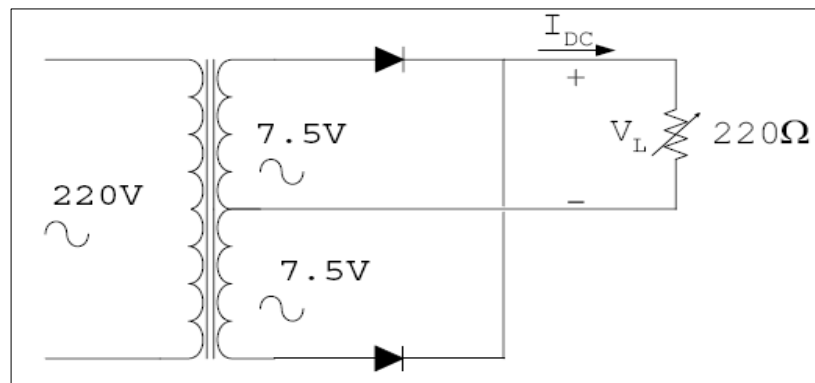

Figure A-2: Full -Wave Center Taped Rectifier

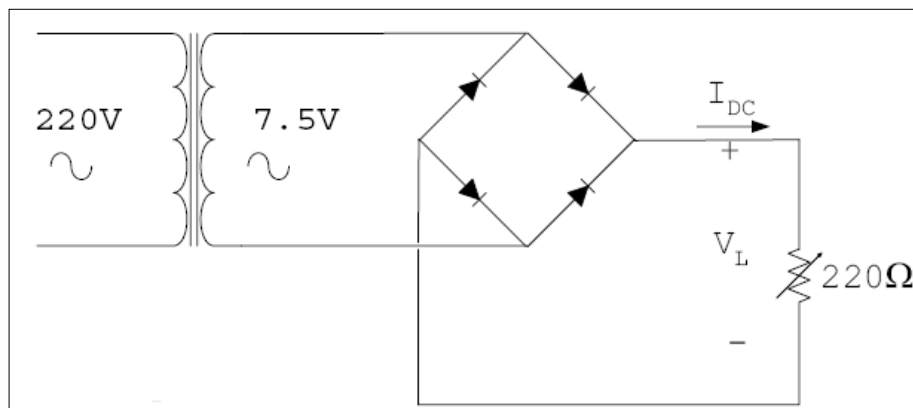

Figure A-3: Full wave Bridge Rectifier

Exercise

- Refer to in-lab 5 exercise A-1

Discussion on Part A

- How is the current rating of the transformer secondary calculated?
- Compare the three circuits for each of the characteristics 1 to 6 listed in the Theory section, and with respect to magnetic polarization of the transformer. What is the regulation mainly due to?
- Under what conditions would each of the circuits be most advantageous?

B. FULL WAVE RECTIFIER WITH CAPACITOR

B1. FULL WAVE RECTIFIER WITH CAPACITOR CALCULATIONS

Calculate the values of V_r and V_{DC} using the approximate relations in the Theory section, with $R_L = 680 \Omega$ and the following values of the capacitor: 1, 22, 100, and 1000 μF . Repeat for $R_L = 2.2 \text{ K}\Omega$. Record your data in Table B.1.

Exercise • Refer to in-lab 5 exercise B-1

B2. FULL WAVE RECTIFIER WITH CAPACITOR MEASUREMENTS

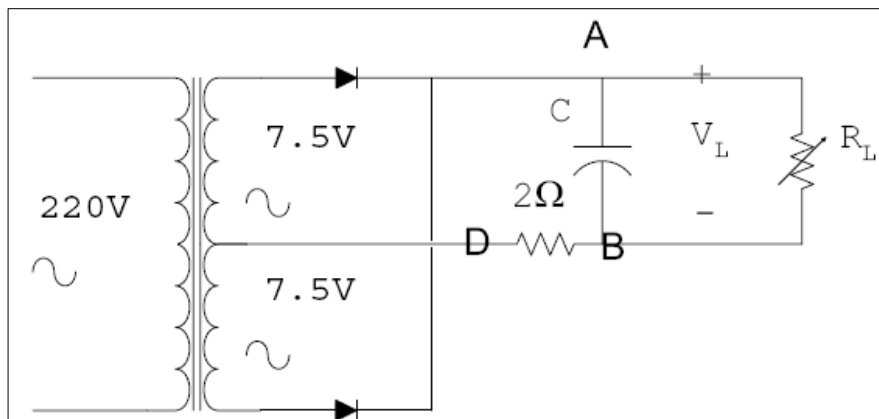

Figure B-1: Full-Wave Rectifier With Capacitor

Refer to the circuit shown in Fig. B-1. Use the oscilloscope to read the AC voltages across AB and BD. With $R_L = 680 \Omega$, measures V_{DC} , I_{DC} , V_r , and I_F (the peak diode current), for the following values of the capacitor: 1, 22, 100, and 1000 μF . Note the period during which diode conducts.

Repeat for $R_L = 2.2 \text{ K}\Omega$. Record your data in Table B.2

C (μF)	$R_L = 680 \Omega$				$R_L = 2.2 \text{ k}\Omega$			
	V_{DC}	I_{DC}	V_r	I_F	V_{DC}	I_{DC}	V_r	I_F
1								
22								
100								
1000								

Table B-1: Full Wave Rectifier Circuit Measurements

Exercise • Refer to in-lab 5 exercise B-2

Plot the following as a function of $10 \log(2\pi f C R_L)$:

- i) V_{DC} / V_{2max}
- ii) V_r / V_{DC}
- iii) I_F / I_{DC}

Compare the measured values of V_r and V_{DC} with those calculated using the approximate relations in the Theory section above.

Discussion on Part B

- Does V_{DC} increase appreciably with C for all values of C ?
- Does V_r decrease appreciably with C for the values of C used in the experiment?
- Does the ratio I_F/I_{DC} vary with C ? Of what practical importance is this ratio?
- Under what conditions are the approximate relations in the Theory section adequate for calculating V_r and V_{DC} ?
- How does the presence of the capacitor affect the regulation of the circuit?
- What additional current rating of diodes must be considered for the capacitor filter?
- For a certain required ripple voltage and DC voltage/current at the load:
 - What should be the RMS voltage rating of the secondary of the transformer?
 - What should be the value of the capacitor?

IV. OUTCOMES

By the end of Experiment V, students:

- Are able to measure and calculate all the characteristics of half wave Rectifier, Full wave Rectifier, and Rectifiers with filters.
- Should understand the different characteristics of rectifiers' circuits and their importance.
- Are able to design a rectifier circuit with capacitor filter.